

# Final Design Proposal

B913210

# Flacks

The Sustainable Flat Pack Shoe

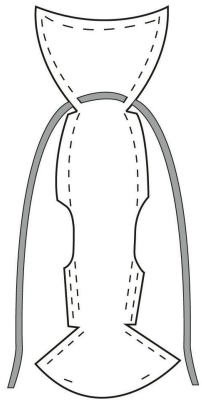

## Flat packed

The shoe when shipped will be in the **clever packaging** allowing them to have a **thin profile**. This makes it **easy to carry**, cheaper to ship and thus **cheaper** for the user to buy.

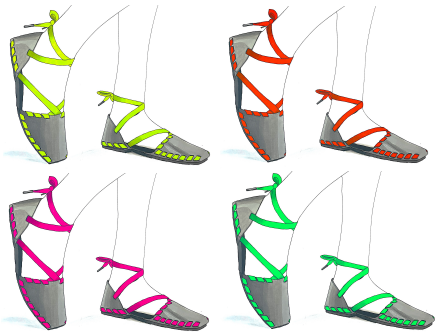

## Customisable

As the laces come in **different colours** and the shoe in **different sizes**. So the user can effectively create their perfect shoe. The laces can be replaced with standard walking boot laces.

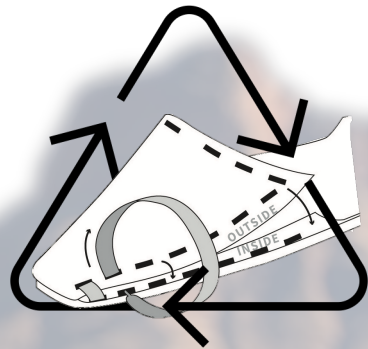

## Recyclable and Replicable

Made from PET and organic cotton, these materials are **recyclable**. The shoe is **easy to separate** into its different materials. Therefore easy to recycle and if one part breaks, you **don't need to replace the whole shoe**. Designed to be worn for 1-2 years.

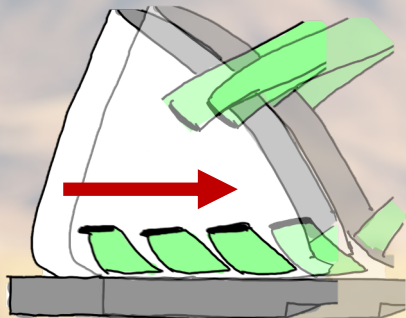

## Expansion

The clever design of the shoe means it can be **elongated**. This is done by the second row of holes in the shoe allowing the heel to be pulled forward. **Great for growing feet**.



# Recap the Problem

## The Problems:

As a child's feet grow quickly when they are young, often families in developing countries will be unable to buy their children footwear as they are **too expensive** and the child will grow out of them.

Having no shoes leaves these children **exposed to sharp objects**, harmful **bacteria or infections** that are in the soil and contaminated water. Without immediate and **expensive treatment**, these can **lead to infection** and chronic illnesses. This may result in amputation or even death.

## The Brief:

"Design a shoe that is more sustainable to deliver to developing countries and lasts longer even with children's fast growing feet."

## Pain Points:



### 1. Growing out of shoes

Children grow so fast that they often have finished with their shoes before they fail.



### 2. Injury when not wearing shoes

Children will cut their feet on the tough ground in developing countries, which often leads to infection.



### 3. Shoes take up a lot of delivery space

Shoe boxes are mostly empty space, and therefore are very unsustainable and expensive to deliver.



### 4. Shoes not being recyclable

Shoes are often not made of materials that are recyclable, which is unsustainable.



### 5. Shoes get broken

As shoes get played with, the material degrades over time. This can often happen sooner in developing countries as they tend to only have one pair of shoes.

## Redesigned User Persona:

Name: Achen Akello

Age: 7

Occupation: Elementary Education



Mother finds it difficult to get shoes for her as the distance to the nearest town is 3 hours away and the shoes there are often expensive. Therefore Achen has to wear her old shoes that no longer fit her. This hurts his feet and doesn't provide her the support she needs. This is still better than not wearing shoes as this keeps her feet safe from being cut, which could lead to infection.

Location: Kito, Uganda

Achen has to walk 2.5 hours each way to school, the roads are a mixture of hot tarmacked roads, which can reach very high temperatures, and dirt tracks that have lots of sharp rocks on them.

Achen says:

"When at school, I love playing football with my friends, there is a field near the school where we all go to play. The field isn't flat with some rocks on it. It isn't possible to play on it without shoes. Therefore I have to use my old shoes to play, but now they are too small for me and I find I get blisters after playing some games."

## Previous Design Opportunities:

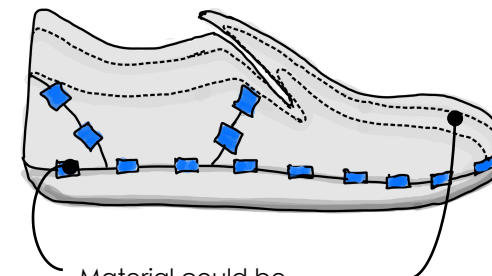

Material could be cut, or undone to separate the two parts

Different sizes of covers, allow for the growth of the child's foot.

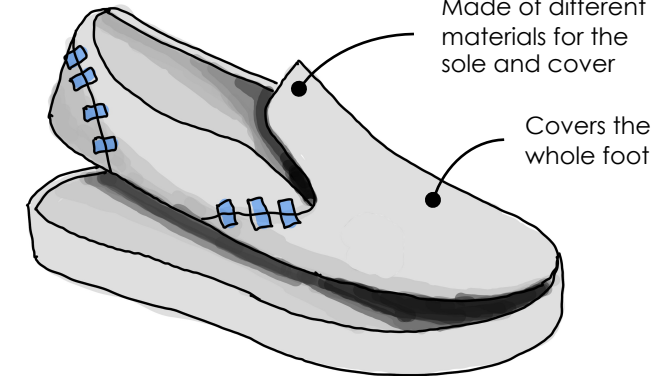

Made of different materials for the sole and cover

Covers the whole foot



## 1. Flat Packed

Having a smaller shoe box increases the number of boxes that could fit on transport at any one time and thus reduce the fuel required per box. It also makes it easier for the user to carry once bought.

A low profile shoe that would reduce the size of the shoe box to make it more sustainable to deliver. A shoe that can be easily assembled by the user.

### Further problems to look into:

How to keep the water and dust out?  
What is the best method to assemble the shoe?



## 2. Different size brackets

The problem is that the material gets damaged over regular use and needs to be replaced. Also children's feet grow.

The design opportunity is to have a shoe where the material on the shoe can be replaced if damaged, and increase in size with the child.

### Further problems to look into:

Will it need to be made in one part or more?  
What sizes are these brackets?  
How does the shoe expand?



## 3. Recycled shoes

Having the shoe made from a recyclable material would be more sustainable.

But the material still has to be durable or replaceable.

### Further problems to look into:

How many materials will it be made from?  
How does Uganda recycle?

# Concept Exploration – Bio-inspired Design

## Customer Needs:

Through the research both in and after the Interim report, a series of customer needs were created. It was felt that if the product managed to hit all these customer needs then the final outcome would be a success. These customer needs are based on the pain points.

1. Must protect the users foot from the hot and rocky ground
2. Must fit the target market of users between the ages of 6-13
3. Must fit the users foot for at least 2 years.
4. Must flat pack small enough to make it deliverable through letter boxes.
5. Must be made from materials that are sustainable.
6. Must be made from materials that won't break as easily as the average shoe so it can last longer.

## The Fastening mechanism:

This is arguably the most important section of the shoe. For without a good fastening mechanism, the shoe couldn't be put on and would be; Not secure or Not flexible.

### Hooks?

Using Biomimicry, it was identified that the burdock plant has lots of tiny hooks on it. This makes it easy for the plant to disperse its seeds as they can be hooked onto animals fur while wondering by. This resulted in Velcro being created.

Velcro wouldn't be good as it has two major flaws. It collects dirt and other felt within, causing it to lose its strength over time. It also damages the surface it's attached to.

Using Biomimicry again, another option could be to look at the mushroom. Due to its shape, the mushroom has the capability to interlock with an inverted mushroom. Like Velcro, it's made from rigid little mushroom-like structures.

This also wouldn't be very good as although it's slightly harder to get dirt and felt stuck in it. But it degrades over time as the material deteriorates.

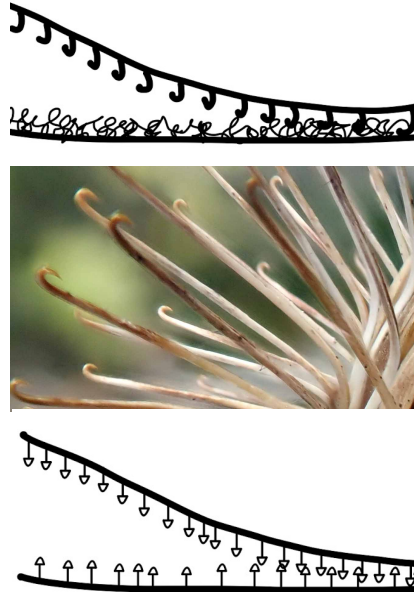

## Concept 1a – Mushroom Slip On:



This Slipper uses a top Velcro part to ensure that the users feet are secured within.

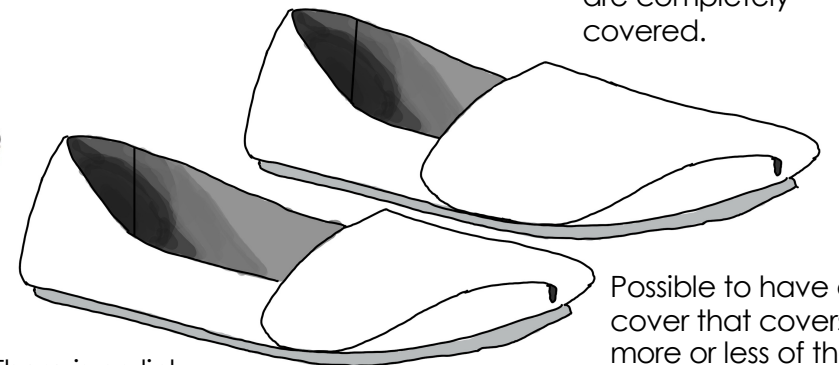

Once the shoe is together, the toes are completely covered.

Possible to have a cover that covers more or less of the foot

There is no link between the back and the sole, therefore a hole for water to get in

The shoe also has no link between the front sides of the shoe, therefore water can get in.

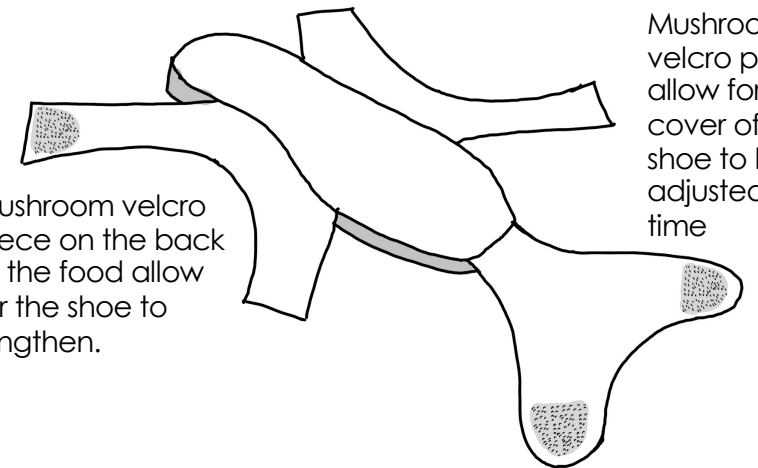

Mushroom velcro piece on the back of the foot allow for the shoe to lengthen.

Mushroom velcro pieces allow for the cover of the shoe to be adjusted each time

## Concept 1b – Mushroom Sandal:

Based on this sandal design. Good ventilation, which is good for keeping feet cool in hot temperatures.



Lots of holes, therefore not very good at keeping out the dirt

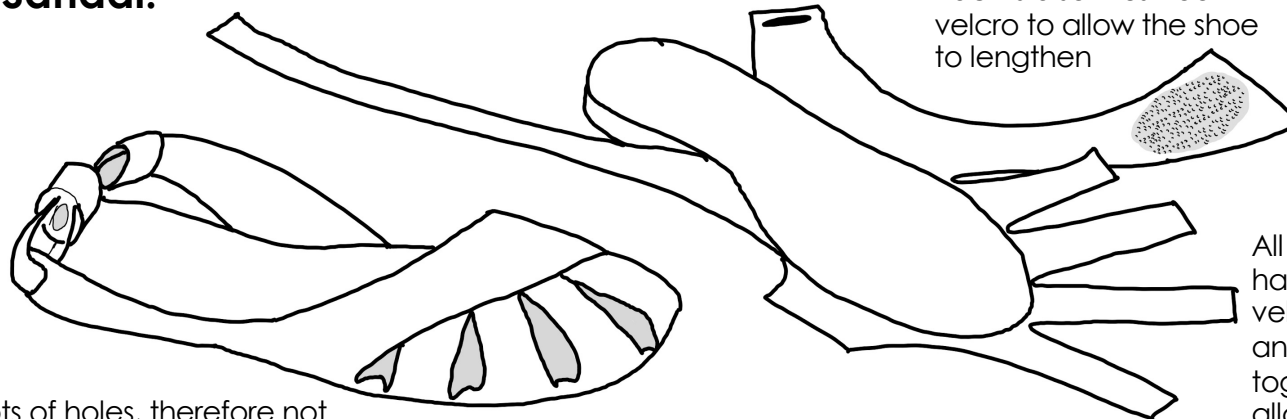

Back is also mushroom velcro to allow the shoe to lengthen

All the strands will have mushroom velcro on the back and will all come together. This will allow each one to be tightened or loosened.

## Summary:

The designs are good although due to the fact that the target market live in Uganda. The mushroom Velcro would get lots of mud, dust and sand in it and thus would stop working. Therefore, this design wouldn't work for the chosen location.

# Concept Exploration - Systematic Inventive Thinking – Task Unification

## Laces:

After listing all the internal and external components laces were chosen as the part to assign an additional task to. The laces on ordinary shoes are very good at tightening the shoe to ensure a good fit about the shoe. But as children's feet grow, the shoe will need to fit the child for many years according to customer needs 3. The additional task is to get the laces to tighten other parts of the shoe.

### Round vs Flat Laces

Round laces:

Advantages: uniform deforming when under tension.

Disadvantage: User can feel it more when pressed against the foot.

Flat laces:

Advantages: More subtle feeling when pressed against foot due to shape

Disadvantage: Dramatic reduction in width when put under tension.



## Concept 2a – Lace Slip On:

Laces are attached all the way around to ensure there are no gaps in the shoe.

Made from one piece of material, therefore less movement in the material which provides better support

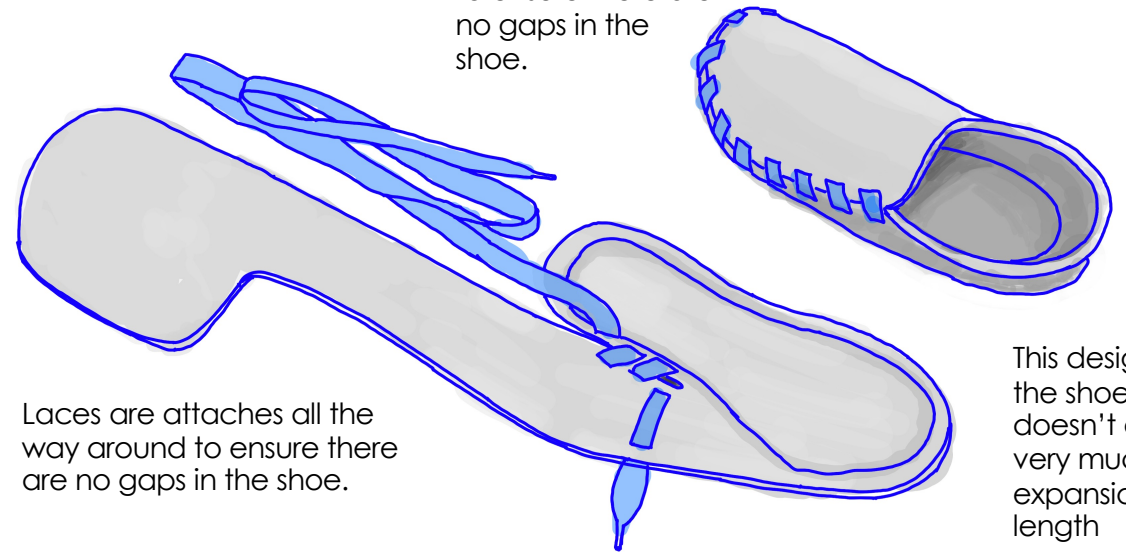

Laces are attached all the way around to ensure there are no gaps in the shoe.

This design of the shoe doesn't allow very much expansion in length

## Concept 2b – Laces all around:



Inspired by this shoe. The total cover provides good protection.

Due to the design, the back can also be pulled in to shorten the shoe. This can be done by missing a hole when assembling it.

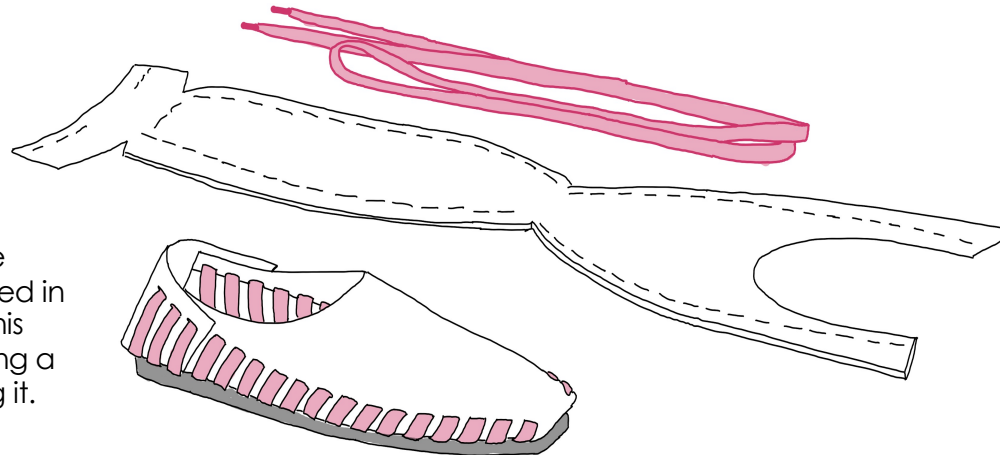

With over lap when joining the materials back on its self. This allows for no gaps when slackening the laces as the child's foot grows.

## Concept 2c – Laces top and sides:



This design was inspired by this shoe. The laces on top allow for better control over the fit of the shoe

With the laces going all around the shoe this allows for the shoe to grow in size, simply by loosening all the laces.

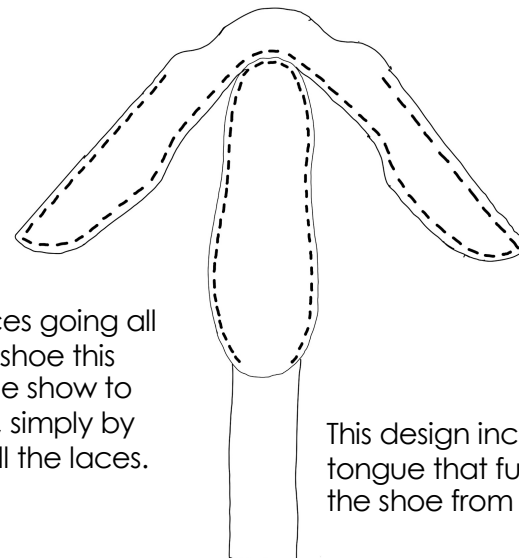

This design incorporates a tongue that further seals the shoe from the outside.

## Summary:

Concept 2a has a good simplistic design although difficult to tighten shoe as all the laces are on one side.

Concept 2c improves upon this by having laces on all sides and in the middle but feel it would be too easy for rocks and sediment to get to the toes.

Concept 2b is the best as it has protection all around. From sediment and can be tightened all around by the laces.

# Development:

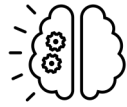

## Systematic Innovative Thinking – Subtraction:

In order to take this idea to the next level, subtraction was used. This was to explore other ways in which the idea could be expanded.

### List of Internal Components:

Creating the list of internal components for a shoe was very difficult due to the limited number of components. But it was still felt this system could be utilised. Therefore, the list of internal components was expanded to incorporate parts of the shoe that wouldn't have been considered a component.

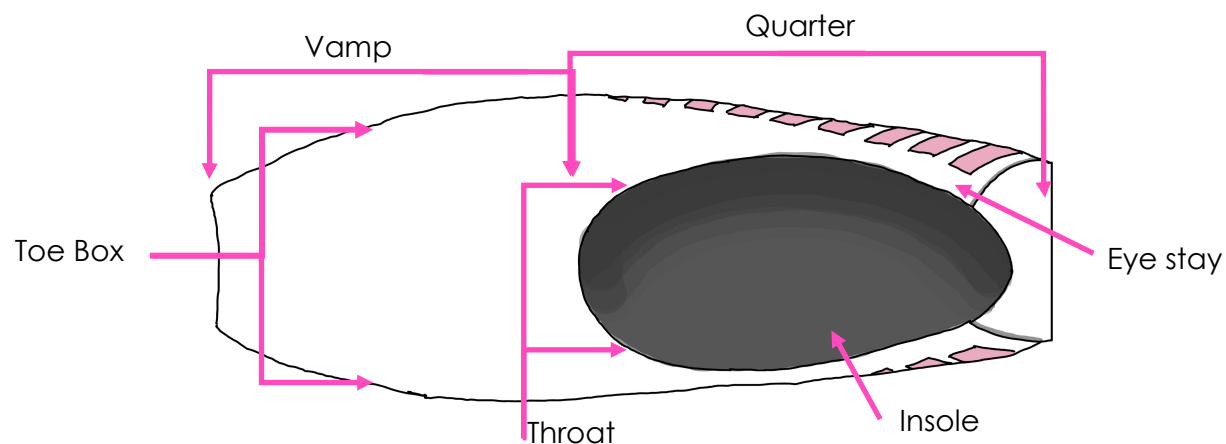
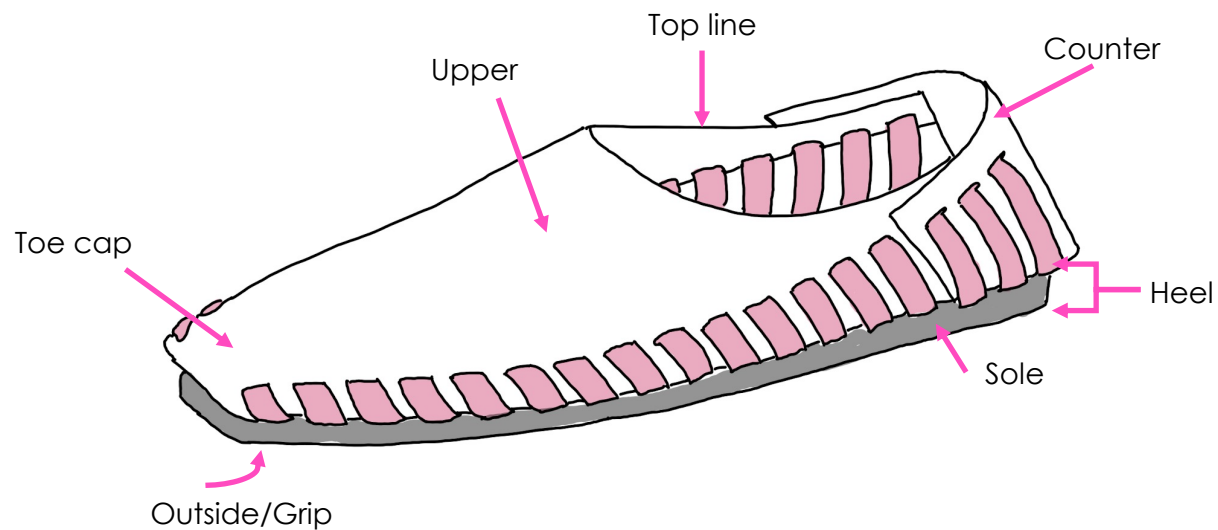

The process of subtracting a few of these components produced lots of designs, but here are the best ones:

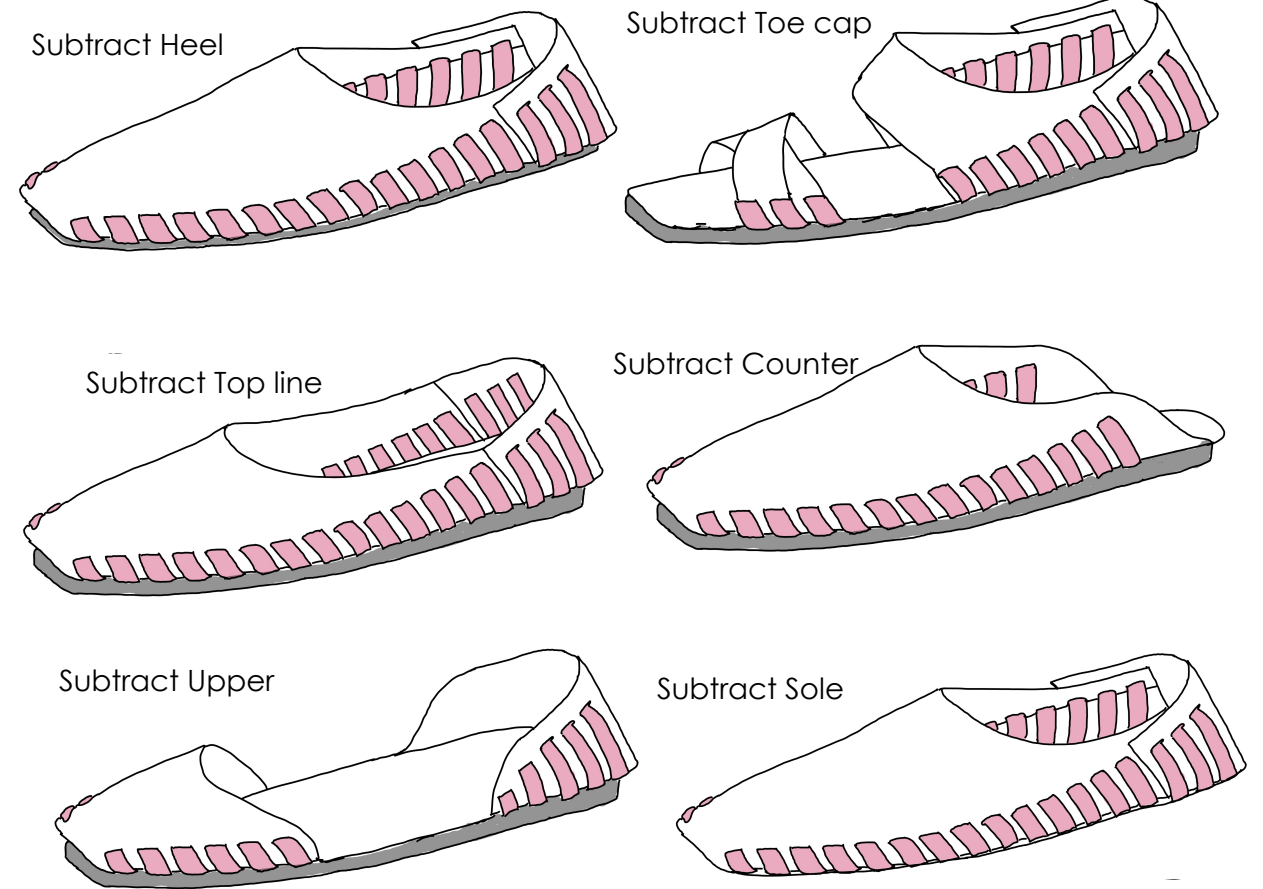

This process produced a few interesting designs. One of particular interest was the subtraction of the upper. This was due to the fact that I still covered the toes and heel. Which are the two main contacts of a shoe in order for it to stay on.

**Problem:** Although the shoe would stay on the foot during normal use, the user persona is a 7 year old girl who loves playing football. Therefore the shoe would need to withstand fast running and kicking of the ball and would require more to secure the shoe to the foot.

# Development:

## ? The Problems, how to hold the foot in place?

As the boy loves to play football which can have large forces on the shoe, therefore wanting it to come off. The potential solution is to find another way of securing the shoe to the foot.

This shoe solves this problem with the use of an additional strap. The strap provides a downward force on the top of the foot therefore preventing the shoe from coming off.

The main USP of this product is the fact it uses shoe laces to tie the whole thing together. Therefore adding an additional strap would not fit with the design of the shoe.

### Possible solutions:

- Create an additional strap to connect the two parts  
This would again not be consistent with the design and make it difficult to assemble and dismantle.
- Add something else like elastics  
Adding extra materials to the shoes only hinders one of its USP (Shoe is only made of a few recyclable materials)
- Use the laces  
This is the best solution as it uses existing components and would allow the user to choose the configuration of the laces over their feet.

Force provided by the strap

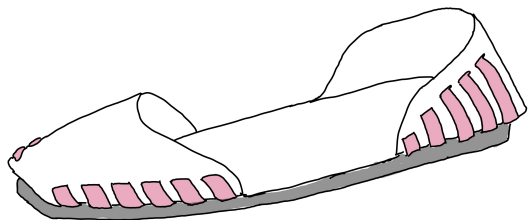

Images of different lace configurations.



Another problem is the speed at which the child can put on the shoe. As there is little chance of the child liking the shoe if it takes them a long time to put on and take off. This is the reason why shoes with Velcro and elastic slip-on's are so popular due to the time it takes to put on and off.

## 💡 The Solution:



Inspired by this ballerina shoe the shoe will have a set of laces come out from the toe and cross over the base of the foot. It will then go back around for one last pass over the lower leg.

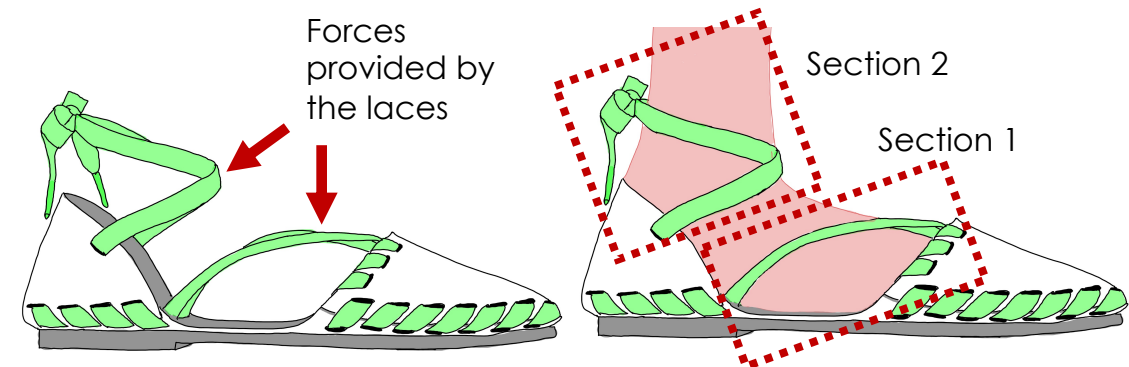

This new design adds two new forces to the shoe to hold the child's foot in. There is an additional downward force in section 1 holding the foot down and a diagonal force in section 2 that holds the child's foot towards the back of the shoe. This in itself will also **add comfort** to the shoe by preventing the child's toes from sliding forward and hitting the front of the shoe, which can cause discomfort.

### Ease of putting on

The laces will also be connected. This means that section 1 and section 2 are connected through the heel. The benefit of this is it allows the user to **tighten both sections at the same time**. As by pulling the section 2 would cause the section 1 to get tighter. This will **speed up the time it takes to put on the shoe** as it only requires one action to tighten all the laces. It also provides better fit over the growth of a child's foot. This is because due to the amount of friction within the other parts shoe and laces, when pulling on the laces in section 2, this shouldn't tighten the other parts of the shoe.

# The Fastening mechanism



## How big or small?

Customer need 3 states that the shoe must be able to **fit the child for more than 2 years**. This was decided as children's shoes are often outgrown within a year of them getting them. Customer need 2 says that it must fit users both male and female between the ages of 6-13. This is because it's the age where education is mandatory in Uganda, and as schools are often very far away it's the age at which they put themselves in most harms way when traveling the 2-3 hours to and from school.

Therefore, according to the Childdata: the handbook of child measurements and capabilities by Beverley Norris these are the mean minimum and maximum dimensions of the foot. The mean was taken as it was felt it would provide a more accurate range as supposed to using the 95 percentiles.



## Ergonomic Data of Children's Feet Against Age

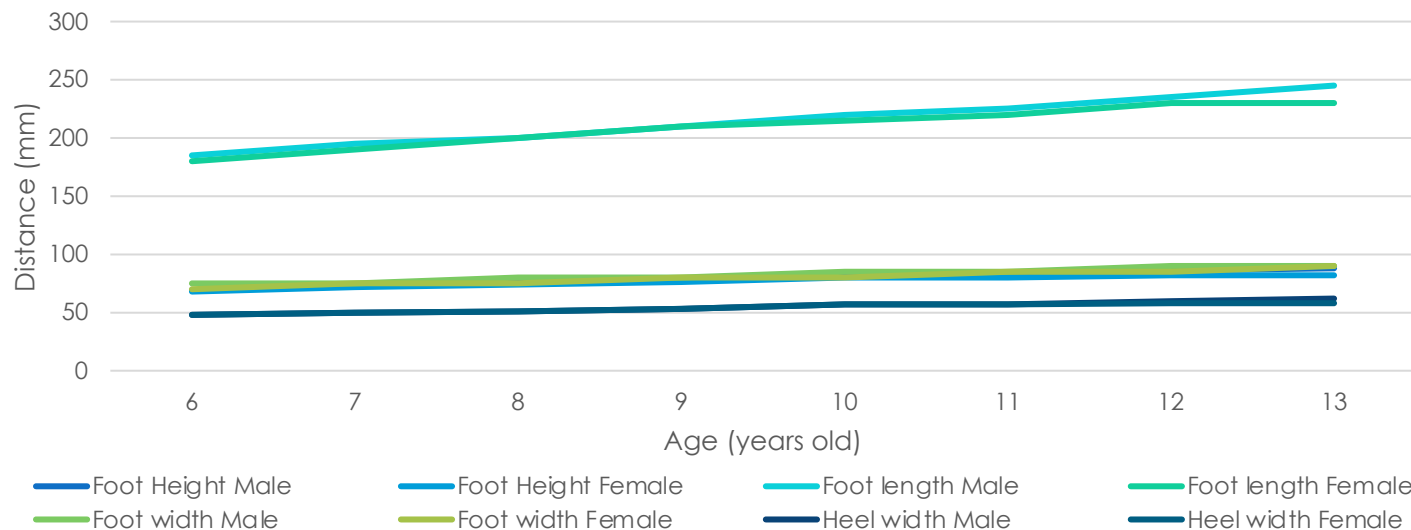

The chart shows that the shoe increasing with age is very linear between the ages of 6-13. Therefore, the shoes will need to expand by the same amount each time. the **shoes growth can be set in linier intervals** instead of exponentially.



## How it grows?

Most shoes if worn every day will only last 1-2 years for adults, and as identified in the research the shoes worn by children tend to only last 0.5-1 year, due to the increase in growth of the child's foot. Therefore to make a more sustainable shoe, if the shoe can **last a child for the full 1-2 years** before the materials degrade, then this would **reduce the waste** of perfectly good shoes. In order for to **account for the growth of the child's foot**. Due the material being flexible there for the shoes should only need to expand in two ways. The length and the width. This is because due to the design of the shoe. The heel width will be accounted for by the flexibility of the material and the extended length. The height of the foot also doesn't need to be taken into consideration as the laces will mean that by slackening them a bit will account for that change in height.

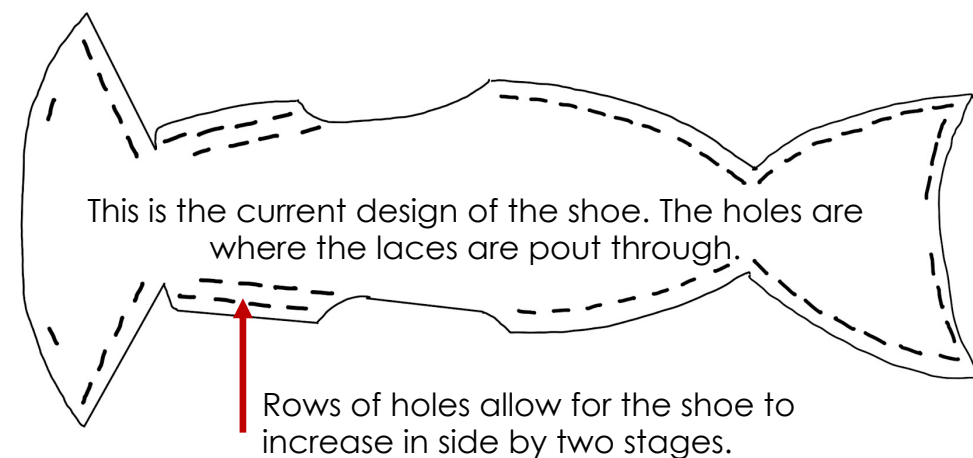

### Toe

Tightening the laces at the front allows the top to come down tighter on the user

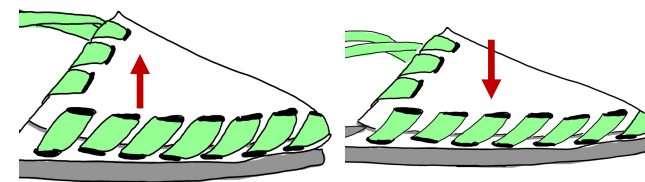

### Heel

The extra row of holes allows for the back to be taken in and out.

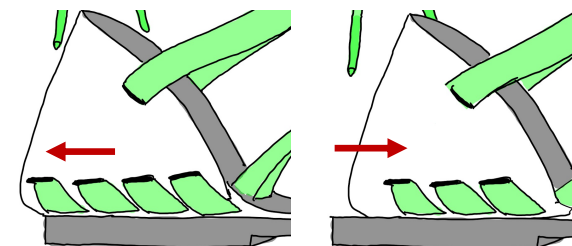

# Development:

## Dust and water proof?

Due to the materials and design the shoe will never be water proof. Although that doesn't stop us from designing the shoe to be more dust proof. Uganda has two rainy seasons a year and is very dry for the rest. Therefore a shoe that can protect against both would defiantly be a benefit the target user.

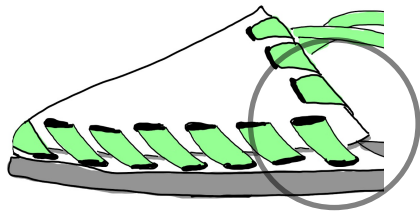

Dust will always come in the sides, but to prevent dust getting into the toes, there could be an over lap between the top surface and bottom surface.

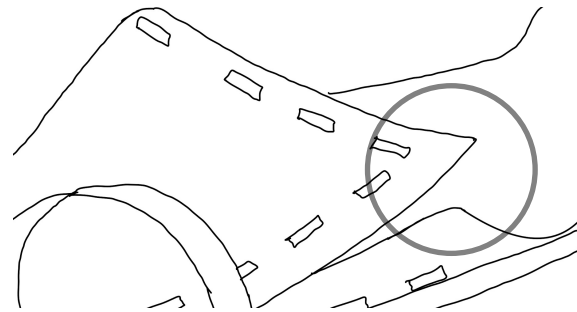

The over lap could also be doubled up to increase the protection. This way the bottom side goes in-between the two top sides.

Although the shoe isn't dust or water proof. These additions to the design will give the user much more comfort when walking.

CAD model done to further visualise the model and identify possible developments.

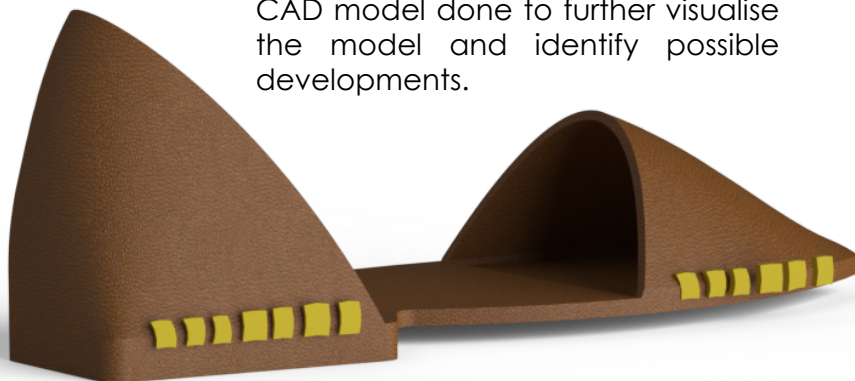

## Materials:

Recycling is an important part of sustainability. Developing countries often do not have the infrastructure to recycle as much as other developed countries do. This is often because they **don't have the ability to separate products into there different materials.**

Therefore, the design of this shoe should be such that it can be made of recyclable materials and that it's **easy for the materials to be separated** so that the shoes are easy to recycle.

Also forcing someone to buy a shoe that is made of non sustainable materials is already setting them back. Therefore the flat packed shoe will use two materials:



### Organic Cotton

Nearly one quarter of the pesticides sold in the world Are used on cotton cultivation represents only 2.4% of the agricultural area.

Therefore by using organic cotton for the laces. Pesticides and chemical fertilizers are replaced by natural compost, and this cotton requires **half as much water** as traditional cotton. The end-result is cotton that is softer, more flexible, and way **kinder to the planet.** Therefore, simply by buying this shoe, they will be helping the planet.

### Polyethylene Terephthalate

The upper and heel of the shoes will be **made from recycled PET plastic bottles.** It's commonly used on the market today in recycled shoes and can be made from plastic water bottles. When recycled, PET goes through a cleaning, grinding, and melting process that results in thread, giving second life to plastic and reducing trash in our landfills. This is then woven into various fabrics. The technology has come so far that we are now able to **mimic animal-based materials** like leather using recycled plastic, too. Again therefore simply by buying the shoes they will be supporting the planet.



**Summary:** Using these recyclable shoes, will allow the users to not only **support sustainable manufacturing** but will also allow them to **recycle there shoes** at the end of there life.

# Extra Development:



## Postage and Packaging

One of the main USP's is that as it's a flat packed shoe. It has a very low profile. This opens the opportunities to reduce the size of the packaging. The Posta Uganda has the following dimension requirements: for a large letter, max weight = 750g, max dimensions= 353x250x25 mm. By fitting the design of the flat packed shoe into these requirements, this will result in **more affordable shipping prices**, which will **lower the final cost** of the product for the user.

That's not all though. As in another attempt to make the delivery as sustainable as possible. The box will also be designed to be utilised after delivers rather than being something that is thrown away. To save on paper and other tools required the box will have two things on the inside:

1. **A chart** to measure both the length and width of the child's foot. This will allow the user to understand which holes the laces will need to go through and provide more information on how to assemble the shoe.
2. **Instruction** on how to assemble the shoe. Using the size of the foot, the user can understand how the shoe is put together using a set of diagrams (see last page).

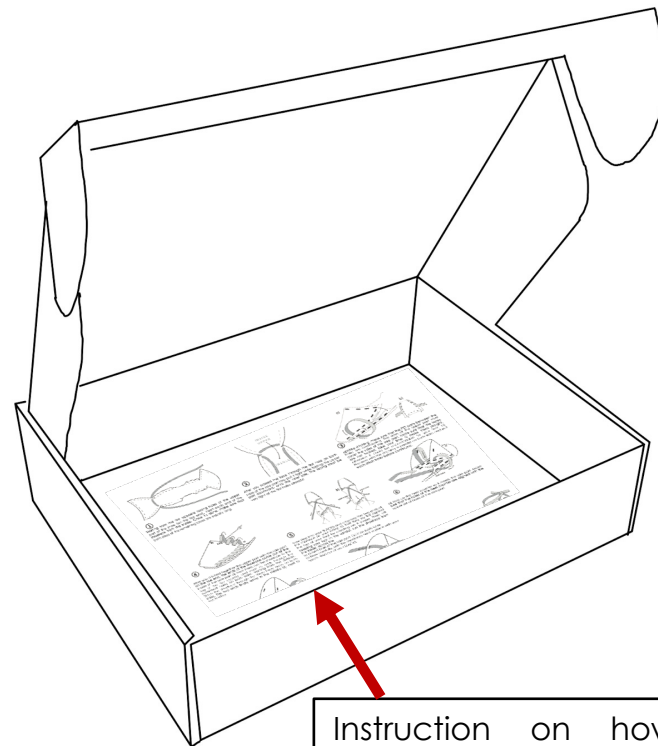
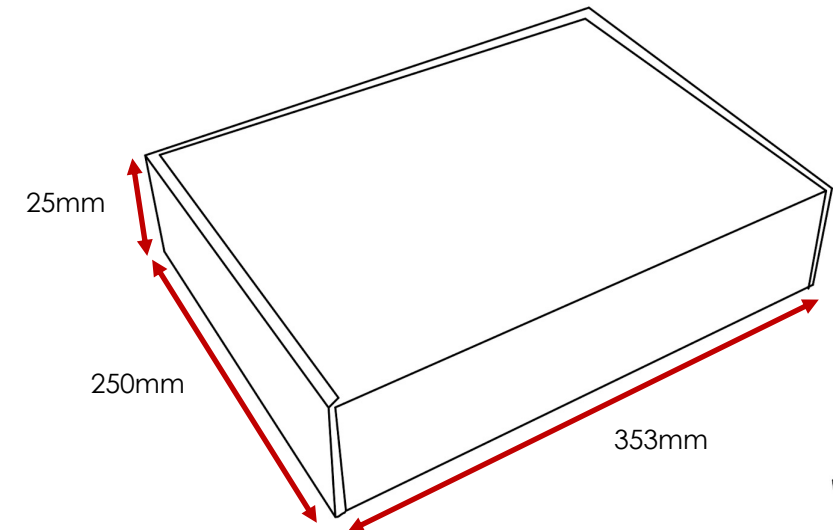

Instruction on how to assemble the shoe printed on the inside of the box (see final page for more detail)

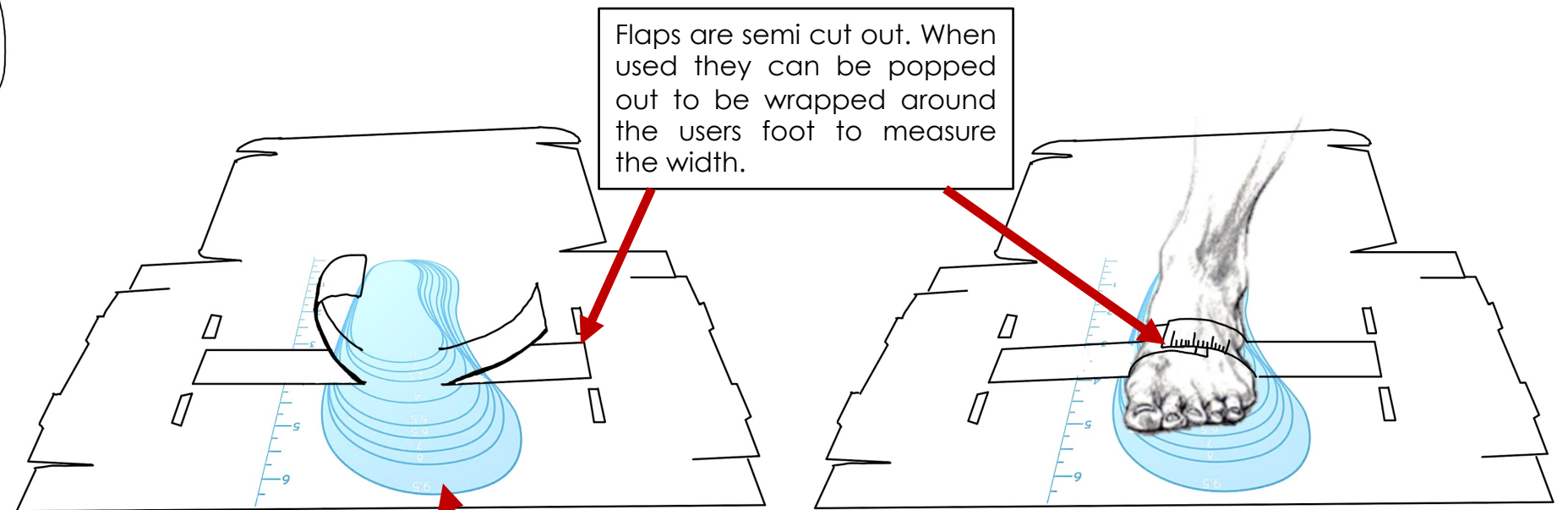

Flaps are semi cut out. When used they can be popped out to be wrapped around the users foot to measure the width.

Printed on the bottom of the box is also chart to measure the size of feet.

# Final Design Proposal

## Unique Selling Points:



### Flat packed

The shoe when shipped will be in the **clever packaging** allowing them to have a **thin profile**. This makes it **easy to carry**, cheaper to ship and thus **cheaper** for the user to buy.



### Customisable

As the laces come in **different colours** and the shoe in **different sizes**. So the user can effectively create their perfect shoe. Can be replaced with standard walking boot laces.



### Recyclable and Replicable

Made from PET and organic cotton, these materials are **recyclable**. The shoe is **easy to separate** into its different materials. Therefore easy to recycle and when one part breaks, you **don't need to replace the whole shoe**. Designed to be worn for 1-2 years.



### Expansion

The clever design of the shoe means it can be **elongated**. This is done by the second row of holes in the shoe allowing the heel to be pulled forward. **Great for growing feet**.

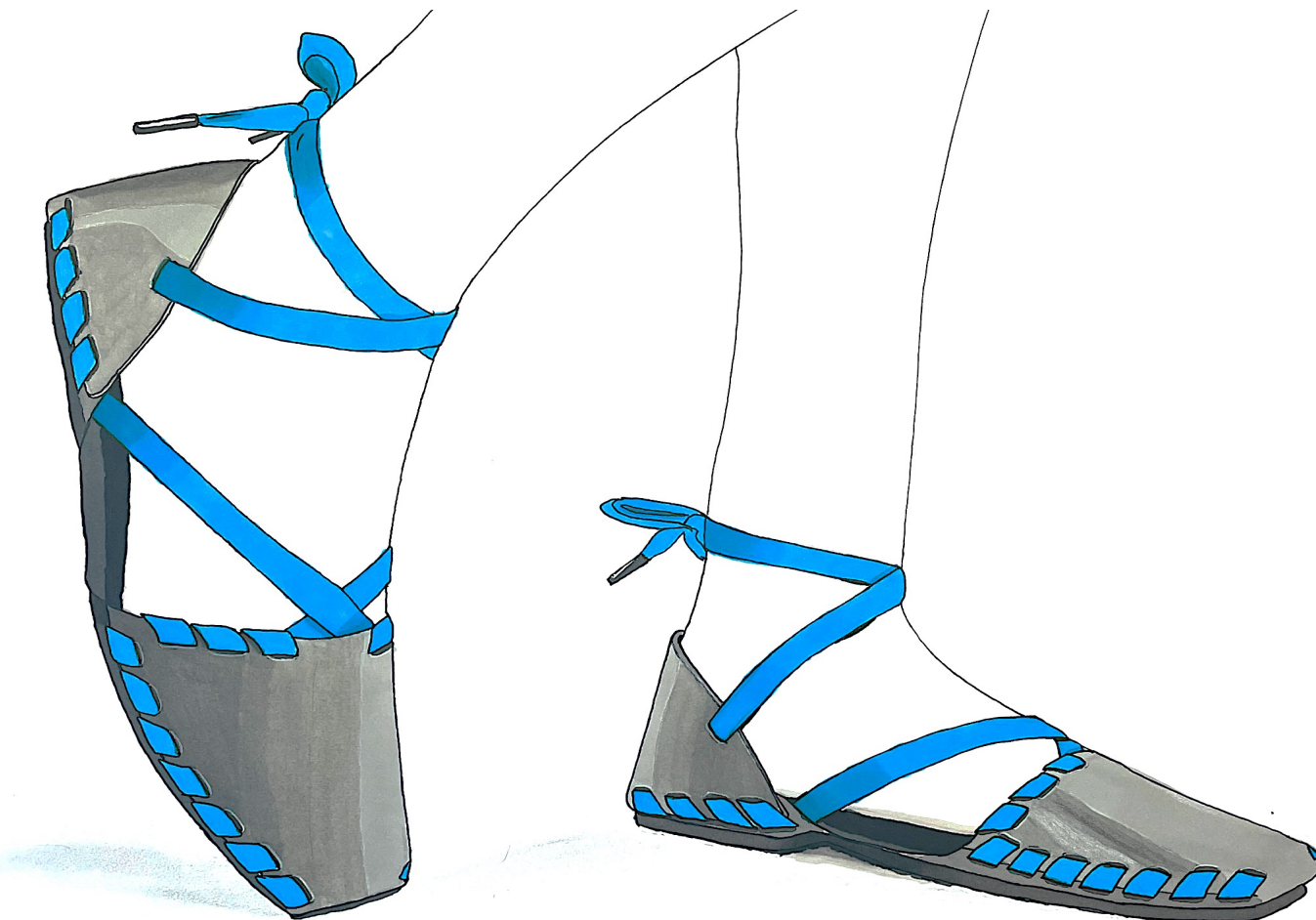

# Flacks

The **brand name** comes from the combination of three words. Flat Pack Shoes. The font it meant to represent shoe laces. The F in the logo is the icon and will also be placed on the back of the shoes for branding.

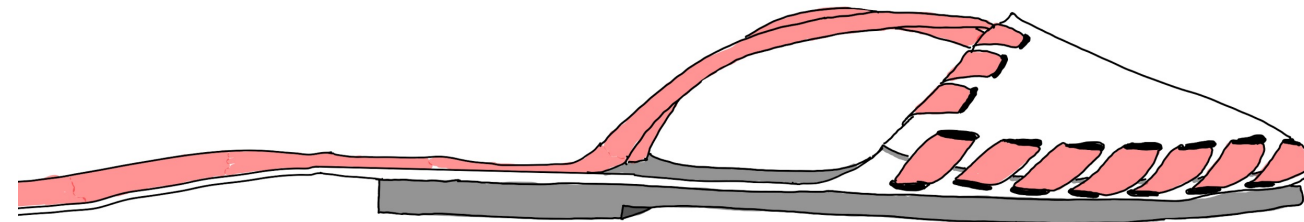

## Design Evaluation:

It was said at the beginning of this report that if the product managed to hit all these customer needs then the final outcome would be a success. These customer needs are based on the pain points:

Must protect the users foot from the hot and rocky ground	With the sole that protects the user from cutting there feet	<input checked="" type="checkbox"/>
Must fit the target market of users between the ages of 6-13	Shoe is designed to fit children between that age range with shoes increasing in linier increments.	<input checked="" type="checkbox"/>
Must fit the users foot for at least 2 year.	The heel can be lengthened by assembling on a different set of hole and the to can be tightened through the laces.	<input checked="" type="checkbox"/>
Must flat pack small enough to make it easier to send and deliver	Due to the size of the shoe, it can fit into the smallest postal packaging, therefore making it easier to send.	<input checked="" type="checkbox"/>
Must be made from materials that are sustainable	Made from PET which can be recycled, and organic cotton laces which are sustainable.	<input checked="" type="checkbox"/>
Must be made from materials that won't break as easily as the average shoe so it can last longer.	It's not, but the design of the shoe allows for the separation of materials which mean that when one part breaks, the whole shoe doesn't need replacing. This means the shoe will last longer.	<input type="checkbox"/>

# Final Design – More info

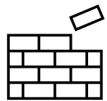

## Assembly Instructions

This is some instruction on how the shoe can be assembled, the diagrams will mean they don't need to be able to read to assemble the shoe. Although can also provide another resource for learning language

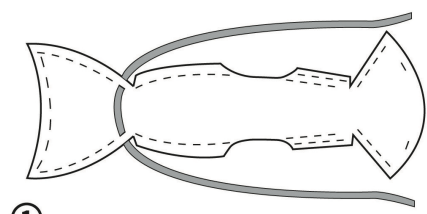

① Starting from the first opposite facing holes of the upper part of the shoe (on the toe end), insert each end of the shoelace from the inside. Once it's done, make sure that both sides of the remaining laces are equally long.

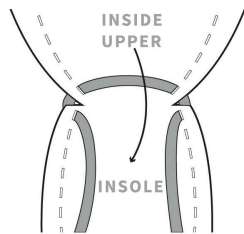

② After you passed the lace through the first hole on both sides of the sole part too, pull it tight while folding the upper part downward, onto the inner sole. The lacing must be very tight at the first holes already!

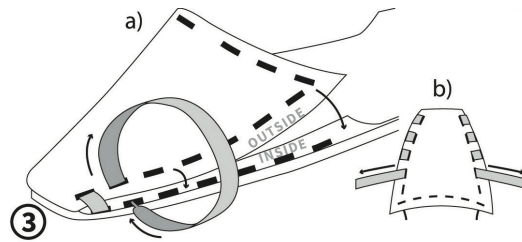

a) While stitching, make sure that the PET parts between the holes are overlapping. The sides of the upper part must cover the sides of the sole part. Make sure that the laces are not twisted, take your time to make them straight, otherwise it could be uncomfortable for your feet. b) Proceed with the stitching in parallel on both sides and pull each stitch firmly before continuing.

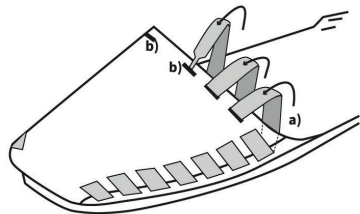

④ After you stitched together the upper part with the sole part on the toe end, the ends of the shoelace come out at the inside of the sole part a). From here, run the shoelace to the top of the toe counter and insert its ends through the outermost holes on both sides, starting from the outside. Stitch the shoelace through the three-three holes on both sides. The two ends finally arrive in the middle b), next to each other.

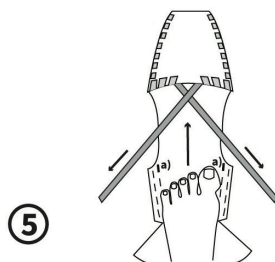

⑤ Now step into your FLACKS and crisscross the two ends of the shoelace on your instep so that they lay flat against the top of your foot by creating an X shape. Then, still keeping your foot in the sandal, run the shoelace from the inside, across the a) closest hole of the sole part. Do it on both sides.

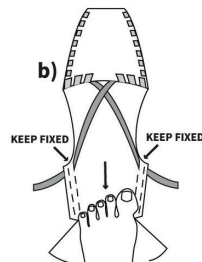

b) Now carefully, with the shoelaces held in place with your hands, step out of your FLACKS.

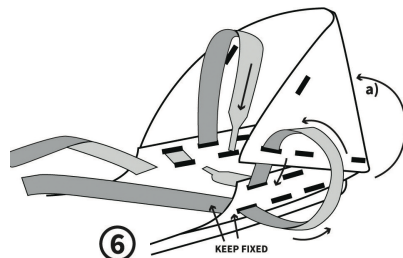

⑥ a) Fold up the heel counter so it meets the sole part. Make sure that the holes of the heel counter are aligned with the upper set of holes of the sole part.

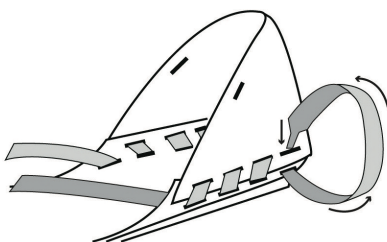

⑦ Stitch the sole part and the heel counter together. Check if the laces are not twisted and make sure that the leather parts between the holes are perfectly overlapping while stitching. Do not forget to pull each stitch firmly before continuing. The ends of the shoelace finally arrive in the inside.

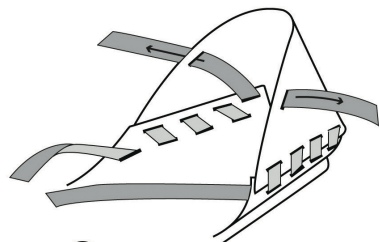

⑧ Then pass the two ends of the shoelace through the two sole holes of the heel counter's upper part so that they come out on the outside.

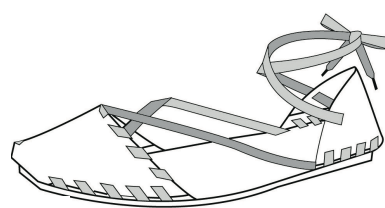

⑨ Step into your FLACKS again, wrap the shoelaces around your ankle and tie a bow at the back. Congrats! Your Slacks Sandal is ready to sport!



## Aesthetics:

In Ugandan culture, colours inherently have a **symbolic nature in a variety of areas**, including when a variety of rich and vibrant colours are used within Ugandan fabrics and clothing. Colours typically can represent a variety of emotions, traditions and victories in the wake of struggles.

The shoe should reflect this with addition of colour to it. Although the shoes need to be a certain colour as to not add costs through printing. One place that colour can be added is through the laces. Therefore over this presentation you have seen the laces represented in bright colours. As the laces are interchangeable, it can be up to the user which colour lace they want.



## Conclusion – Future comments:

To conclude, if there was more time and more pages to write on. Somethings to look into could possibly would be creating a take back scheme. As the product will be made of PET which is recyclable and the shoe would come in its own packaging. The product could be designed that once the shoe is done you buy a new one, and then send the old one back to the manufacturers.

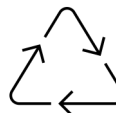

Another idea is as the designs are so simple, to save further on the transportation of the shoe to Uganda, the designs could be sold to a manufacturing plant in Uganda for them to make.